

Datasheet

Mestic LiFePO4 lithium battery MLBS-100 LN5 smart

The Mestic Lithium batteries deliver smart technology, high performance and maximum safety for every camper, caravan or leisure boat. Their weight is up to 50% less compared to traditional AGM or gel batteries and built with premium Grade A prismatic LiFePO4 cells. LiFePO4 cells ensure stability, long lasting power and excellent durability. With smart connectivity and a compact design, you can enjoy reliable energy wherever you travel, without compromise.

Features

- **Built in heating for charging in extreme cold conditions:** the integrated heater ensures safe charging under 0 °C.
- **Compact, customized casing in standard LN5 size:** space saving ABS housing with shock resistant and fire retardant construction, to fit the limited space of your vehicle (e.g. under the seat of Fiat Ducato).
- **Detachable cover with removable SAE terminal poles:** for easy installation and service.

Communication

- **Built in display:** always instant insight without a smartphone: charge level, status messages and warnings via LED indicators and on/off button.
- **Full smart connectivity:** WiFi, Bluetooth®, RS485, CAN and CiBus for seamless system integration, real time monitoring and advanced control.
- **Mestic smart app for instant insight:** wireless monitoring of capacity, voltage, temperature and charge status, supported by smart diagnostic tools.

BMS and Protection

The intelligent Smart BMS (Battery Management System) provides complete battery protection for safe and stable performance in every situation. It prevents overcharge, over-discharge, overcurrent and overheating, while advanced cell balancing ensures long term reliability even under heavy loads.



MLBS-100 LN5 smart

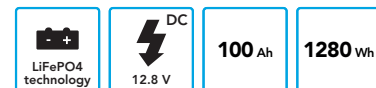

- LiFePO4 lithium technology for high power and maximum safety
- Integrated BMS and advanced communication interfaces
- Heating function for charging down to minus 20 °C
- Long life cycle (>3500 cycles at 100% DoD)
- IP65 waterproof class
- LED status display
- Durable and safe ABS housing with compact design
- Lightweight and maintenance free
- 5 year warranty



Works seamlessly with
the Mestic smart app

WiFi Bluetooth



Datasheet

Mestic LiFePO4 lithium battery MLBS-100 LN5 smart

Product

Article No.	1518940
EAN-code	8712757494521

Electrical data

Nominal voltage	12.8 V
Open circuit voltage	13.2 V
Nominal capacity	100 Ah
Capacity tolerance	2%
Capacity @ 20 A	300 min
Energy	1280 Wh
Resistance	<10 mΩ
Self-discharge	<3% per month
Cycle life (at 1C, 25 °C, 100% DoD, 80% EoL)	>3500 cycles

Charging performance

Recommended Charge voltage	14.2~14.6 V
Charge Cut-Off voltage	14.8 V (3.7 V/cell)
Reconnect voltage	13.52 V (3.38 V/cell)
Balancing voltage	>3.4 V / cell
Recommended Charge current	30 A
Maximum Charge current	100 A
Maximum batteries connection	4 in series / 8 in parallel

Discharging performance

Discharge Cut-Off voltage	10 V
Reconnect voltage	11.6 V
Maximum continuous Discharge current	100 A
Peak Discharge Cut-Off Current	125 A@5 sec, 140 A@200 msec
End of Discharge Voltage	11.2 V
Short circuit protection	500 μs

Mechanical data

Weight	11.2 kg
Case material	PC/ABS (UL94 V-0)
IP-class	IP65
Cell type	Prismatic/LiFePO4
Terminal type	M8/SAE

Temperature performance

Charge temperature	-20~50 °C
Discharge temperature	-20~55 °C
Storage Temperature	-20~55 °C
BMS High temperature Cut-Off)	90 °C
Reconnect temperature	90 °C
Operation Relative Humidity	0-95%

Dimensions

Dimensions (L x W x H)	355 x 175 x 190 mm
DIN standard	H8/LN5

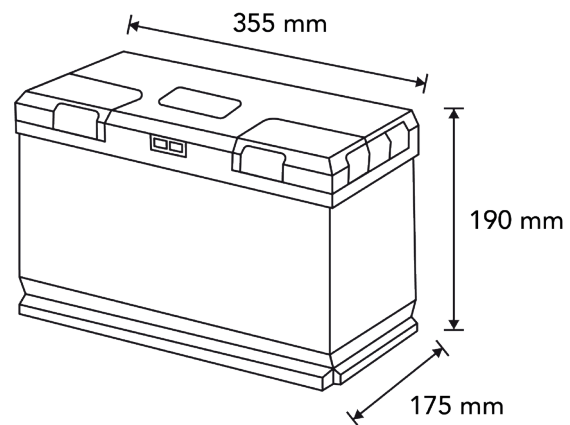

Compliance data

Certifications	CE, IEC61219, UN38.3, RoHS, MSDS, ECE R10
Shipping classifications	UN 3480; Class 9